

# TRUCK PALLET SCALE



Truck pallet scale is designed for fast and accurate mass measuring of loads with multiple tarring in all measuring range.

The truck is powered by batteries (operation time, approximately 12 hours). The charger is standard equipment of the scale.

The truck pallet scale is offered with 5-keys keyboard and LED display as standard.



Counting pieces



Checkweighing



Summing function

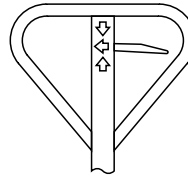

- ⇩ lowering
- ⇐ drive
- ⇧ lifting

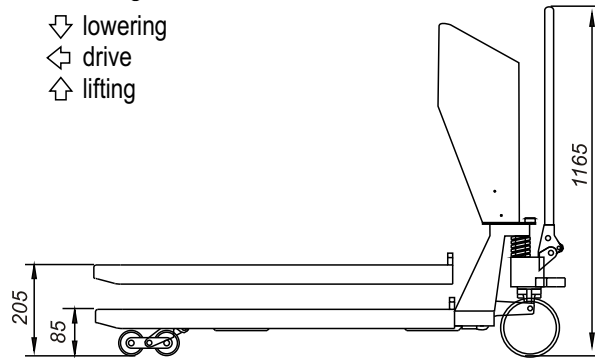
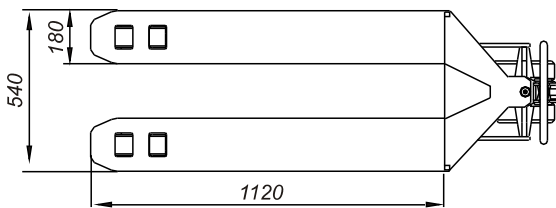

## Technical data:

	WWT 4.500S	WWT 4.1000S	WWT 4.2000S
Max capacity	500 kg	1000 kg	2000 kg
Readability	200 g	500 g	1000 g
Tare range	-500 kg	-1000 kg	-2000 kg
Beam length	1120 mm		
Beam positioning	bottom: 85 mm, top: 205 mm		
Working temperature	0° - +40 °C		
Output signal	RS 232 (option)		
IP rating	IP 65		
Power supply	12V battery		
Display	LED		
Mass	~120 kg		

## PARTNER CORPORATION S.R.L.

Str. Mures nr. 63 sector 1 Bucuresti ROMANIA  
 Telefon/Fax: 021-224.09.95 021-224.14.74  
 021-224.22.57

[www.partner.com.ro](http://www.partner.com.ro)

[office@partner.com.ro](mailto:office@partner.com.ro)

DISTRIBUTOR: